



SCAM VACUUM PUMP

SCAM pumps are mainly used for vacuum production in steam condensing plants.

Many thousands of SCAM pumps have been already manufactured.

SCAM pumps have always been favoured by many Customers in Thermal and Thermo-Nuclear, Petro-Chemical Plants and Steel Mills.

As a reference, it must be said that in Italy they have been installed in all the major Thermo-electric Power Plants.

A Thermal Power Plant performance depends on the ratio between the hot source and the cold source temperature. Thermo technicians have always tried to increase this ratio that, however, is linked to the difference between the fuel oil combustion temperature (in Conventional Power Plants) and the cold source temperature (usually sea, lake, river water or atmospheric air).

Actually, the difference is a theoretic limit that cannot be reached because of the presence of many obstacles, that we try to avoid or reduce since they decrease the Plant efficiency increasing, on the other hand, the actual cold source temperature.

An important obstacle is represented by the presence of incondensable in the steam condenser that works under vacuum, deriving from the re-entry of small quantities of air and from the degassing of process fluids. The elimination of these incondensables can be obtained with the use of water or steam ejectors either of liquid ring pumps, but in liquid ring pumps it is not very reliable.

SCAM air pump keeps the incondensable at a very low level with the best efficiency in reliability and consumption.

SCAM air pump intakes in a high vacuum degree, a mixture saturated with air and saturating steam at a much higher temperature to the plant cold water.

Exploiting the mixture compression, the SCAM pump works by means of liquid pistons created by the rotation of a blade impeller.

The continuous technological development and the recent modifications brought on the SCAM pump and on vacuum auxiliaries, which it is integrated to make the pump suitable for all kinds of applications.

On the other hand, SCAM air pump also solves vacuum problems starting from high pressure.

The quantity of incondensable penetrating in the steam circuit, is linked to the manufacture imperfections and to the quality of the fluids present in the cycle; since it is generally impossible to make a reliable estimate, data of international rules - such as the H.E.I. rules are consulted.

The steam intake quantity depends on the condenser thermal variations and on the climatic and operative conditions.

Consequently, the application range of the SCAM pump is extremely wide. Approximately, the reference conditions that can be mentioned correspond to an intake of 50 Kg/h of air and 100 Kg/h of saturated steam at a 50 mbar absolute pressure.

Our pump, because of its operating conditions, is the most suitable equipment to intake gas mixtures rich of steam.

SCAM
Torino

OPERATING PRINCIPLES

The SCAM pump works as a hydraulic turbine with partial injection operated by an electric motor.

The water arriving axially in the water inlet body enters radially the impeller, passing through an element with a rectangular section called distributor.

The drain takes place when the impeller blades run in front of the distributor. Thus, slightly concave and few millimetres thick water blades are formed.

The incondensable and the saturating steam to suck are trapped among the water blades and are led to the drain, where they are expelled from by a deaeration system - shown in the general arrangement - consisting of a convergent diffuser where the fluid re compression takes place.



DESCRIPTION OF THE SCAM PUMP

The pump consists of

- a static part including:

- Water inlet body dwg1 ref 17
- Pump body dwg 1 and diffuser dwg 2 ref 42
- Water inlet chamber and distributor dwg 1 ref 14 and 21
- Bearing box dwg 1 ref 4

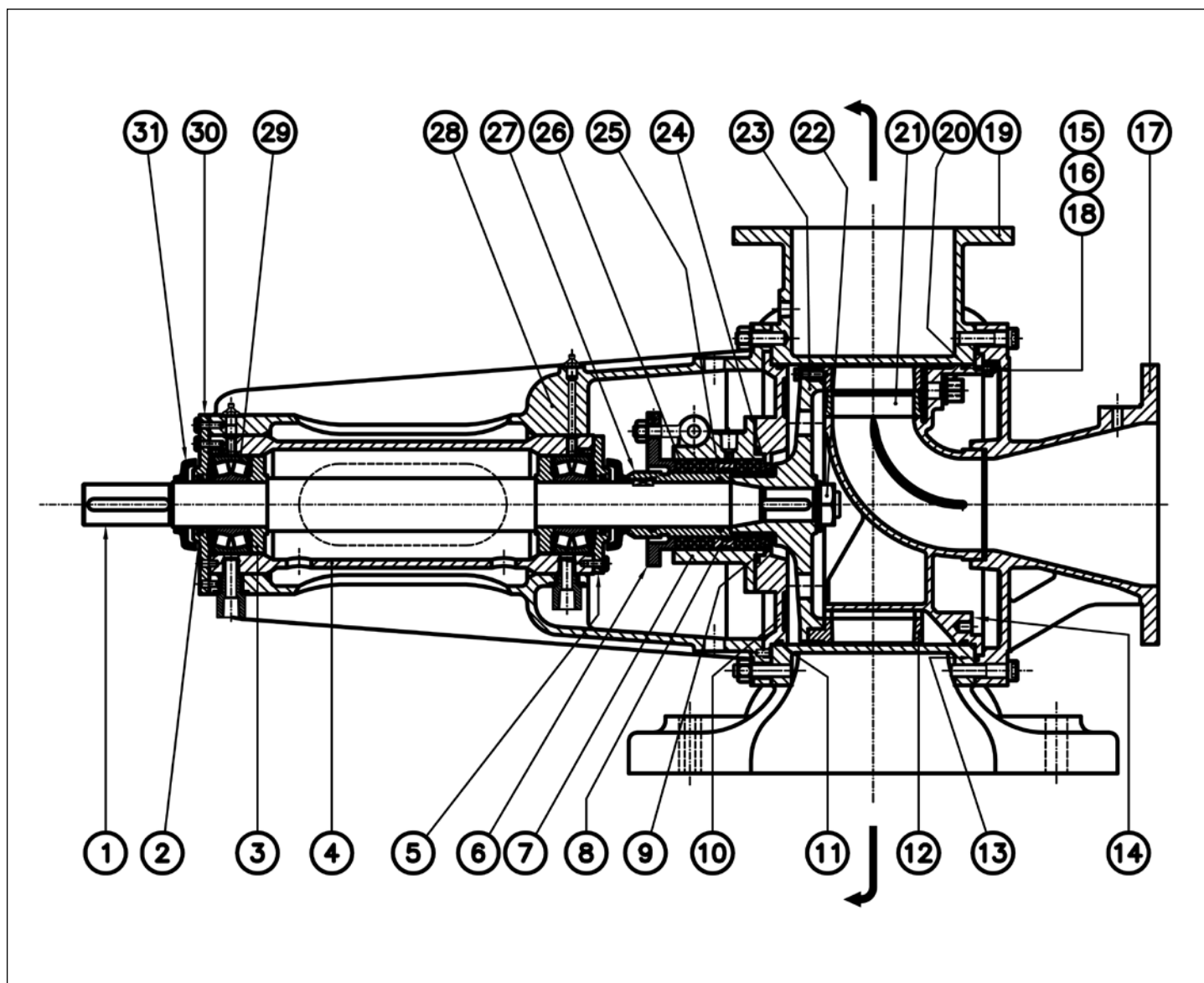

DWG 1

SCAM
Torino

- a movable part including:
 - shaft dwg. 1 ref. 1;
 - blade impeller assembled on the impeller holding disc, both set overhanging on the shaft dwg 1 ref 12-23
 - The mechanical power is supplied by the coupling of an electric motor

In the SCAM pump the water, active fluid, is used as thin blades produced at regular intervals. These blades work as small pistons compressing the gas mass among them.

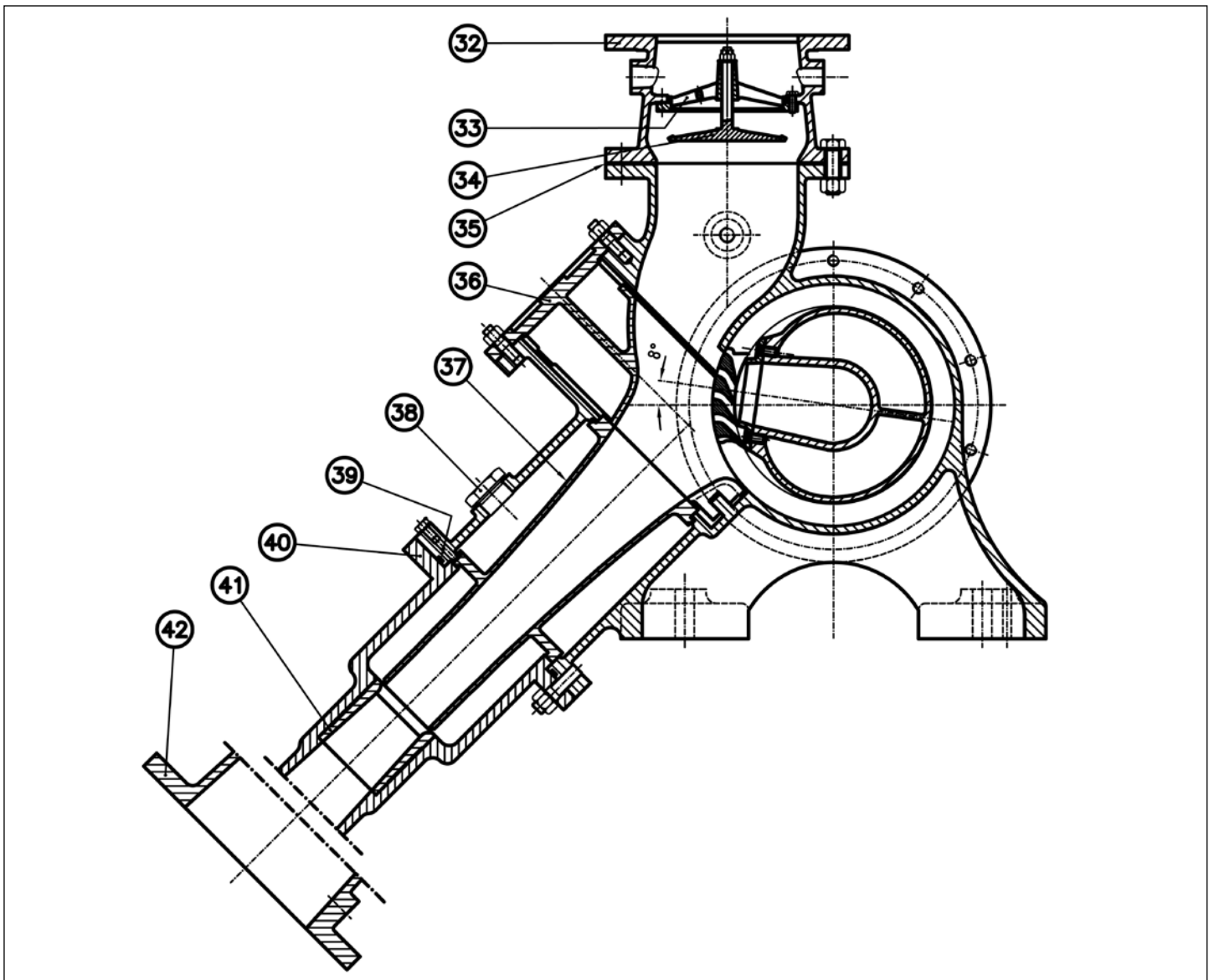

DWG 2

GENERAL ARRANGEMENT

The water needed for the pump operation can be taken from:

- a channel
- a tank.

A) Channel Supply (dwg. 3)

The installation of this system is quite inexpensive, but the water output of the pump is wasted; it is necessary to increase the motor power since the pump works in taking.

Also, this solution needs a primer system for the pump at start-up.

B) Tank Supply (dwg.s 4 and 5)

With this solution, the pump operating water circulates in closed circuit, i.e. the water full of gas is returned through the diffuser to the tank.

In the tank, the deaerated water is sent to the pump.

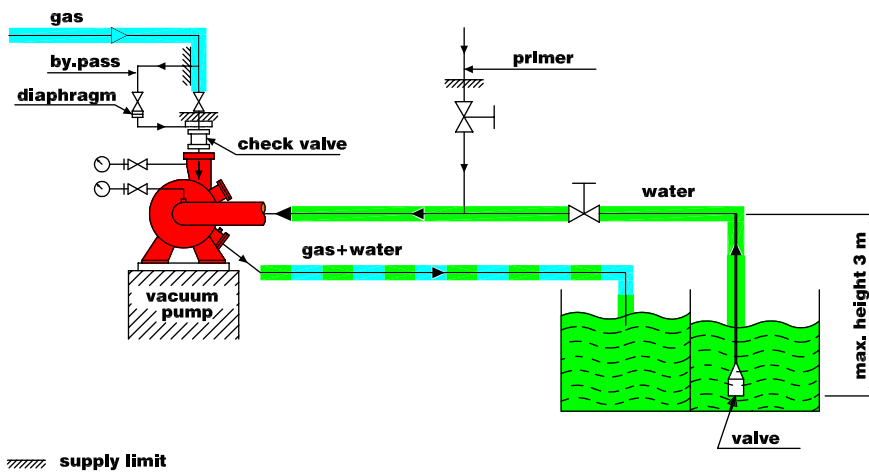

Dwg. 3 - General Arrangement of a Vacuum Pump-Channel Intake

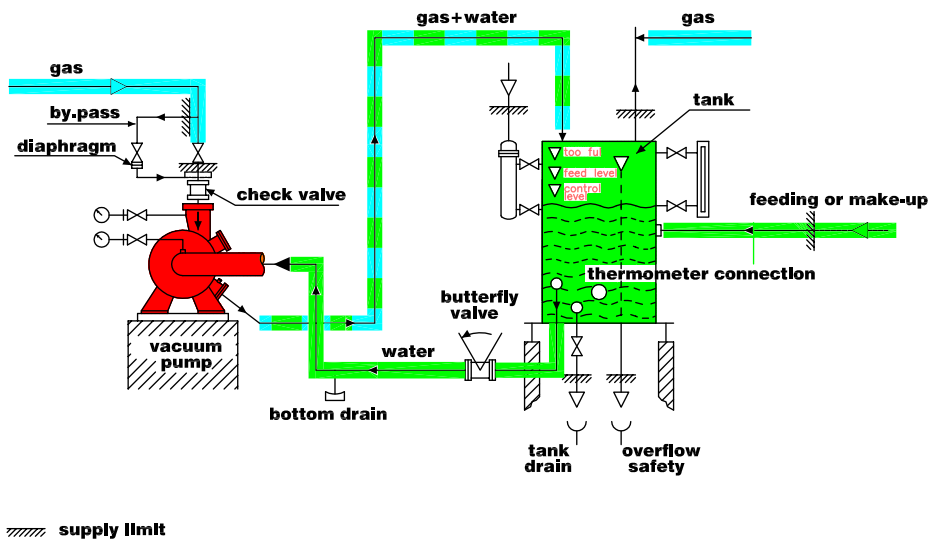

Dwg. 4- General Arrangement of a Vacuum Pump with Mixing Cooling Tank

The water, working in closed circuit, overheats: actually, it catches the calories produced by the pumping and the condensation of the steam that saturates the gases. In order to keep constant the operating water temperature, it is necessary to cool it in the following way:

- by mixing with a cold water make-up (dwg. 4);
- by a heat exchanger included in the tank (dwg. 5).

It should be noticed that this cooling process is used in Thermo Nuclear Power Plants for vacuum groups in order to obtain two separate circuits:

- 1 st circuit: pump operating water;
- 2nd circuit: cooling water.

This cooling system results also very convenient when only sea water as a cooling fluid is available.

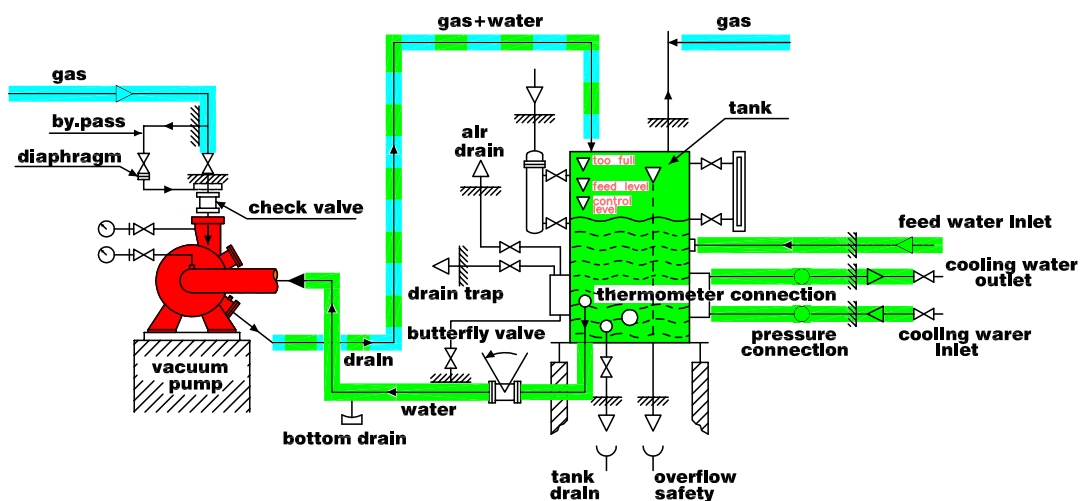

////// supply limit

Dwg. 5- General Arrangement of a Vacuum Pump with Surface Cooling Tank



SCAM
Torino



SCAM
Torino

MANUFACTURING MATERIALS

PRODUCTION RANGE

SCAM pumps are manufactured with suitable materials in order to avoid any corrosive phenomena of their parts in contact with gas or feed water.

SCAM pumps range from WL 0000 type with a 2 kW power to WL21 type with a 75 kW power.

The choice of a kind of pump for a vacuum production is linked to these criteria:

- dry air weight to suck in kg/h;
- absolute pressure to keep;
- cooling water temperature.



Since this water temperature is generally very near to the cooling water temperature of the condenser in which the vacuum is needed, the dry air capacity is particularly linked, according to a certain load to the vacuum corresponding to the different circulating water temperatures (see dwg. 6 - Performances Curves).

Another quality of the SCAM vacuum pump is its stoutness: actually, it does not have any gaskets between moving parts, except a stuffing box. Its mechanical design does not require any reduced tolerance or complex shaped parts.

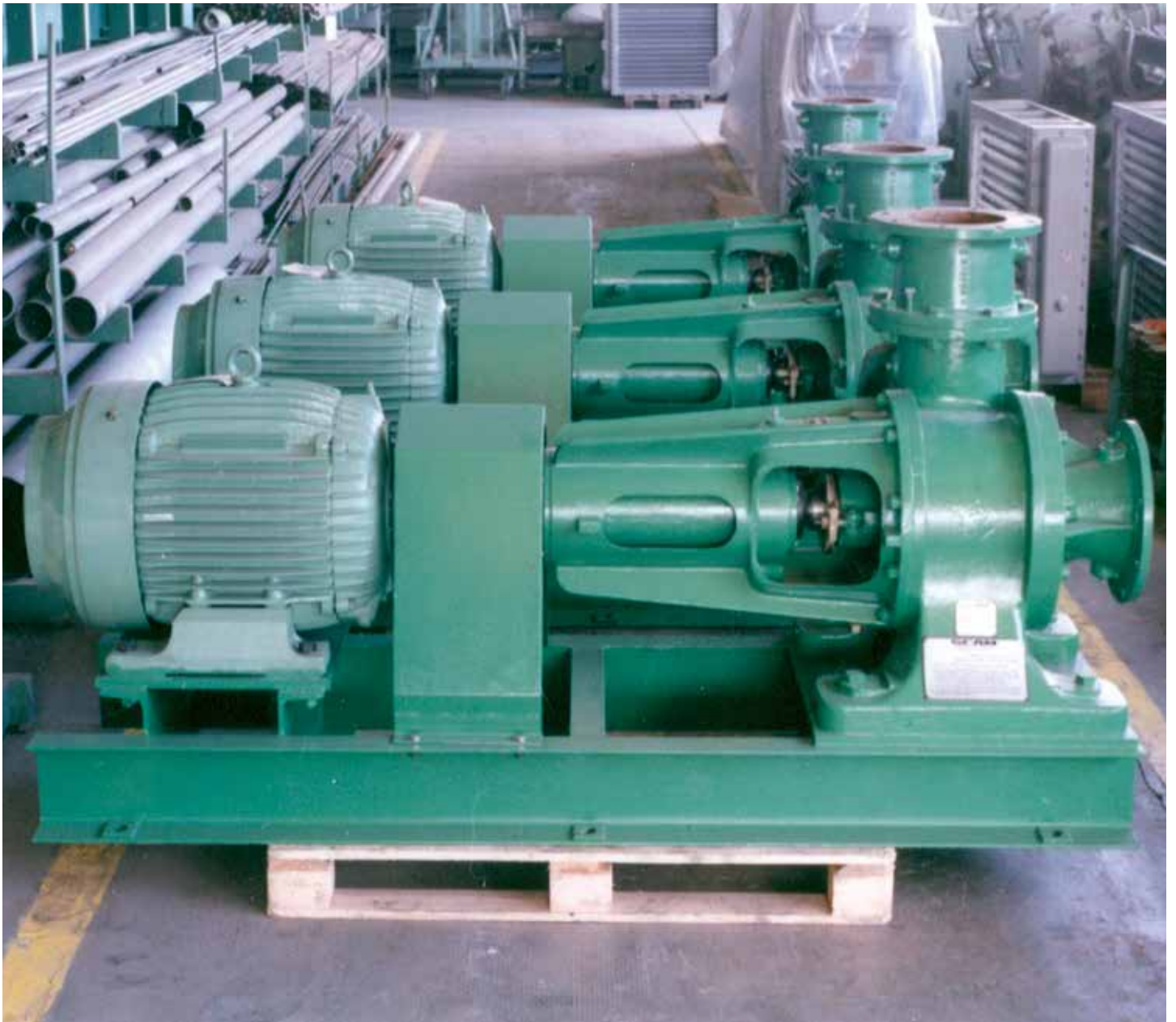

TECHNICAL FEATURES OF THE PUMPS

The basic difference among SCAM pumps, steam ejectors and positive-displacement pumps (vane and O-ring pumps) is due to the fact that the steam intaken contemporaneously from the air is condensed by the pump operating water.

The gas volume compressed between the two water blades and discharged in the atmosphere represents the pump real pneumatic capacity and it is measured in dry air Kg/h.

The value of this intaken air load is constant even if the air draws with it a large steam mass (twice or three times the air mass).

The pneumatic capacity of the SCAM pump is due to the difference between the inlet pressure and the saturating pressure corresponding to the operating water temperature.



APPROXIMATE SIZE OF THE MOTOR-PUMP GROUP FOR THE DIFFERENT SCAM PUMP TYPES

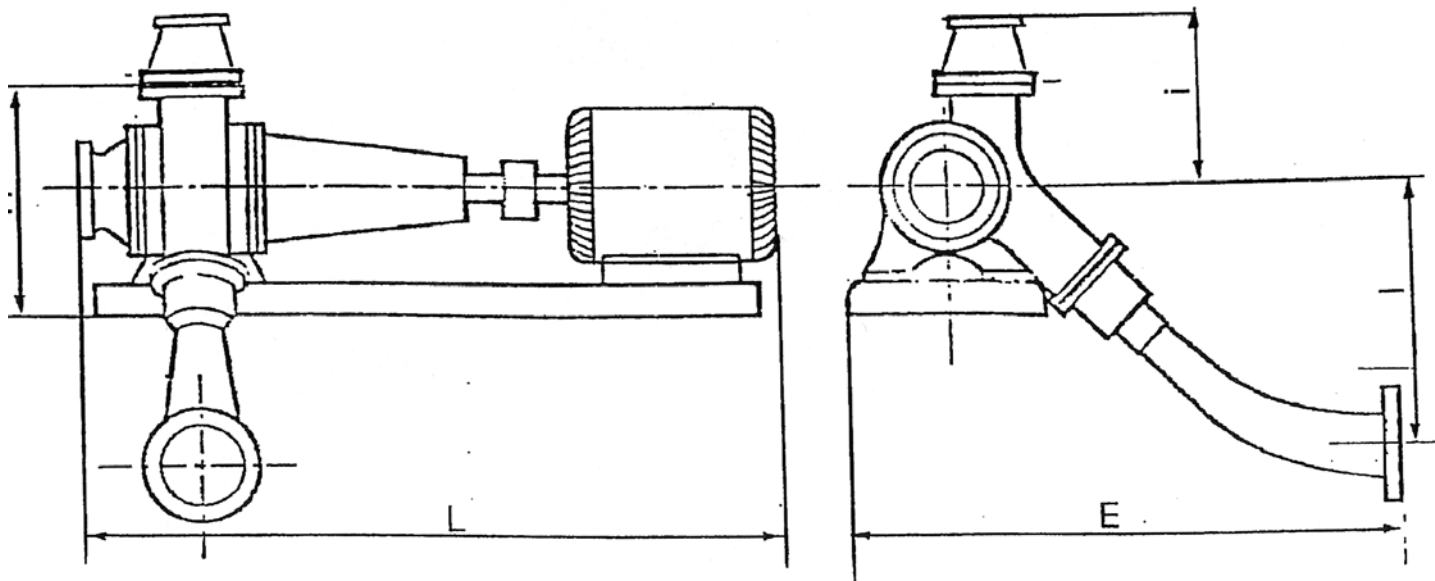

Type	WL 0000	WL 000	WL 1	WL 2	WL 3-4	WL 5	WL 6	WL 7	WL 8	WL 9-10	WL 11	WL 12	WL 13-14	WL 15-16	WL 17	WL 18 R	WL 18 Ax	WL 21 R	WL 21 Ax
H	360	725	670	670	670	670	700	750	1075	1075	1075	750	850	1050	1050	1050	1050	1465	1465
I	127	450	450	450	450	450	300	340	725	725	725	340	340	620	620	520	520	830	830
E	525	570	1250	1260	1260	1260	1260	1260	1700	1220	1220	1700	2250	1730	1730	2300	2300	2500	2500
I	380	525	400	400	400	400	400	550	850	550	550	550	932	1817	932	940	940	1600	1600
L	995	1140	1650	1800	1800	1800	1800	2200	1620	1620	1620	2200	2400	2300	2300	2400	2250	3100	3100
RPM	295	1450	1450	1450	1450	1450	1450	1450	1450	1450	1450	1450	1450	1450	1450	1450	1450	980	980
Ab. power	2	4	6	7	9	9.5	11	12	13	15	16	19	22	26	35	37	37	75	75
Weight	80	300	500	530	530	550	550	630	650	680	680	680	1400	1450	1500	1500	1500	2400	2400

- Absorbed power in kW
- Approximate sizes in mm.
- Approximate weight of the complete groups.

The mentioned technical data are not binding and SCAM S.p.a. may modify them without any obligation or advance notice.

SCAM
Torino



SCAM
Torino



Reference Summary

Since 1930 we have been manufacturing:

- 10820** Air and Compressed Air COOLERS
- 1600** Oil COOLERS and Air COOLERS
- 485** Water/Water, Hydrogen and Oxygen COOLERS
- 810** Water, Air and Oil RADIATORS
- 17420** STEAM EJECTORS (Single and Multiple stages) and THERMOCOMPRESSOR
- 1515** VACUUM PUMPS
- 1200** DESALINATION PLANTS
 - Steam evaporating system
 - Reverse Osmosis for brackish and sea water
- 1069** Fuel and surface CONDENSERS and EJECTOR-CONDENSERS
- 2920** HEAT EXCHANGERS
- 152** DEAERATORS
- 123** DESUPERHEATERS
- 20950** Water, Air and Oil FILTERS
- 165** SALINOMETERS
- 1750** *SHIPS equipped by our plants*

SCAM

SCAM S.p.a.

Head Offices And Works

Corso Orbassano 368/24
10137 Torino - Italy
Phone +39-011-3111665
Fax +39-011-3110134

Account Department

Corso Orbassano 368/18
10137 Torino - Italy
Phone +39-011-306986
Fax +39-011-307088

Web site: www.scam-spa.com

E-mail: scam-commerciale@scam-spa.it
scam-vapore@scam-spa.it
scam-vuoto@scam-spa.it
scam-refrigeranti@scam-spa.it
scam-amministrazione@scam-spa.it